

### Description

The [SP3222E](#) and [SP3232E](#) series are RS-232 transceiver solutions intended for portable or hand-held applications such as notebook or palmtop computers. The SP3222E / SP3232E series has a high-efficiency, charge-pump power supply that requires only 0.1μF capacitors in 3.3V operation. This charge pump allows the SP3222E / SP3232E series to deliver true RS-232 performance from a single power supply ranging from 3.0V to 5.5V. The SP3222E / SP3232E are 2-driver / 2-receiver devices. This series is ideal for portable or hand-held applications such as notebook or palmtop computers. The ESD tolerance of the SP3222E / SP3232E devices are over ±15kV for both Human Body Model and IEC61000-4-2 Air discharge test methods. The SP3222E device has a low-power shutdown mode where the devices' driver outputs and charge pumps are disabled. During shutdown, the supply current falls to less than 1μA.

### FEATURES

- Meets true EIA/TIA-232-F standards from a 3.0V to 5.5V power supply
- Minimum 120kbps data rate under full load
- 1μA low power shutdown with receivers active (SP3222E)
- Interoperable with RS-232 down to a 2.7V power source
- Enhanced ESD specifications:
  - ±15kV Human Body Model
  - ±15kV IEC61000-4-2 Air Discharge
  - ±8kV IEC61000-4-2 Contact Discharge

Ordering Information - [Page 21](#)

### Typical Applications

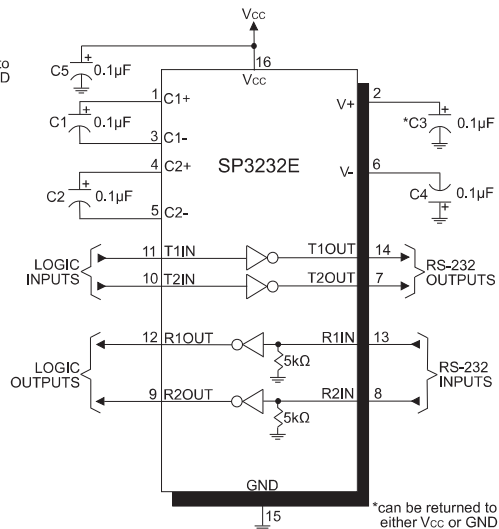
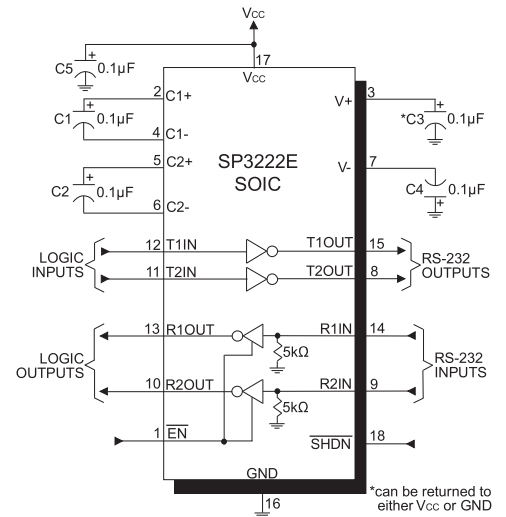
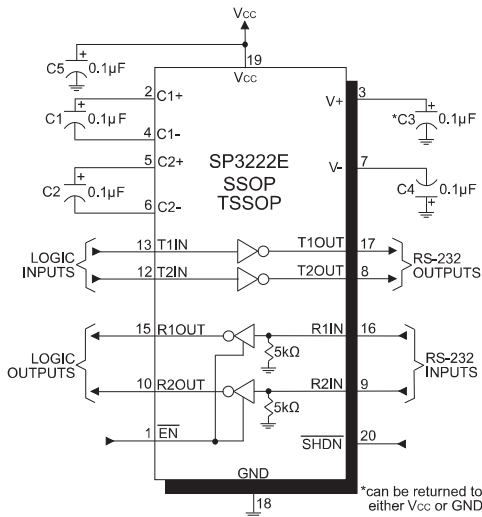

### Absolute Maximum Ratings

These are stress ratings only and functional operation of the device at these ratings or any other above those indicated in the operation sections of the specifications below is not implied. Exposure to absolute maximum rating conditions for extended periods of time may affect reliability and cause permanent damage to the device.

V<sub>CC</sub>.....-0.3V to 6.0V  
 V<sub>+</sub><sup>(1)</sup>.....-0.3V to 7.0V  
 V<sub>-</sub><sup>(1)</sup>.....0.3V to -7.0V  
 V<sub>+</sub> + |V<sub>-</sub>|<sup>(1)</sup>.....13V  
 I<sub>CC</sub> (DC V<sub>CC</sub> or GND current).....±100mA

#### Input Voltages

TxIN,  $\overline{\text{EN}}$ ,  $\overline{\text{SHDN}}$ .....-0.3V to (V<sub>CC</sub> + 0.3V)  
 RxIN.....±25V

#### Output Voltages

TxOUT.....±13.2V  
 RxOUT.....-0.3V to (V<sub>CC</sub> + 0.3V)

#### Short-Circuit Duration

TxOUT.....Continuous

Storage Temperature.....-65°C to +150°C

#### Power Dissipation per package

20-pin SSOP (derate 9.25mW/°C above 70°C).....750mW  
 18-pin SOIC (derate 15.7mW/°C above 70°C).....1260mW  
 20-pin TSSOP (derate 11.1mW/°C above 70°C).....890mW  
 16-pin SSOP (derate 9.69mW/°C above 70°C).....775mW  
 16-pin PDIP (derate 14.3mW/°C above 70°C).....1150mW  
 16-pin WSOIC (derate 11.2mW/°C above 70°C).....900mW  
 16-pin TSSOP (derate 10.5mW/°C above 70°C).....850mW  
 16-pin NSOIC (derate 13.57mW/°C above 70°C)..1086mW

#### NOTE:

1. V<sub>+</sub> and V<sub>-</sub> can have maximum magnitudes of 7V, but their absolute difference cannot exceed 13V.

### Electrical Characteristics

Unless otherwise noted, the following specifications apply for V<sub>CC</sub> = 3.0V to 5.5V with T<sub>AMB</sub> = T<sub>MIN</sub> to T<sub>MAX</sub>, typical values apply at V<sub>CC</sub> = 3.3V or 5.0V and T<sub>AMB</sub> = 25°C.

PARAMETERS	MIN.	TYP.	MAX.	UNITS	CONDITIONS
<b>DC Characteristics</b>					
Supply current		0.3	1.0	mA	no load, V <sub>CC</sub> = 3.3V, T <sub>AMB</sub> = 25°C, TxIN = GND or V <sub>CC</sub>
Shutdown supply current		1.0	10	µA	SHDN = GND, V <sub>CC</sub> = 3.3V, T <sub>AMB</sub> = 25°C, TxIN = V <sub>CC</sub> or GND
<b>Logic Inputs and Receiver Outputs</b>					
Input logic threshold LOW			0.8	V	TxIN, $\overline{\text{EN}}$ , $\overline{\text{SHDN}}$ <sup>(2)</sup>
Input logic threshold HIGH	2.0		V <sub>CC</sub>	V	V <sub>CC</sub> = 3.3V <sup>(2)</sup>
Input logic threshold HIGH	2.4		V <sub>CC</sub>	V	V <sub>CC</sub> = 5.0V <sup>(2)</sup>
Input leakage current		±0.01	±1.0	µA	TxIN, $\overline{\text{EN}}$ , $\overline{\text{SHDN}}$ , T <sub>AMB</sub> = 25°C, V <sub>IN</sub> = 0V to V <sub>CC</sub>
Output leakage current		±0.05	±10	µA	Receivers disabled, V <sub>OUT</sub> = 0V to V <sub>CC</sub>
Output voltage LOW			0.4	V	I <sub>OUT</sub> = 1.6mA
Output voltage HIGH	V <sub>CC</sub> - 0.6	V <sub>CC</sub> - 0.1		V	I <sub>OUT</sub> = -1.0mA
<b>Driver Outputs</b>					
Output voltage swing	±5.0	±5.4		V	All driver outputs loaded with 3kΩ to GND, T <sub>AMB</sub> = 25°C
Output resistance	300			Ω	V <sub>CC</sub> = V <sub>+</sub> = V <sub>-</sub> = 0V, T <sub>OUT</sub> = ±2V
Output short-circuit current		±35	±60	mA	V <sub>OUT</sub> = 0V
Output leakage current			±25	µA	V <sub>CC</sub> = 0V or 3.0V to 5.5V, V <sub>OUT</sub> = ±12V, drivers disabled

## Electrical Characteristics (Continued)

Unless otherwise noted, the following specifications apply for  $V_{CC} = 3.0V$  to  $5.5V$  with  $T_{AMB} = T_{MIN}$  to  $T_{MAX}$ , typical values apply at  $V_{CC} = 3.3V$  or  $5.0V$  and  $T_{AMB} = 25^{\circ}C$ .

PARAMETERS	MIN.	TYP.	MAX.	UNITS	CONDITIONS
<b>Receiver Inputs</b>					
Input voltage range	-15		15	V	
Input threshold LOW	0.6	1.2		V	$V_{CC} = 3.3V$
Input threshold LOW	0.8	1.5		V	$V_{CC} = 5.0V$
Input threshold HIGH		1.5	2.4	V	$V_{CC} = 3.3V$
Input threshold HIGH		1.8	2.4	V	$V_{CC} = 5.0V$
Input hysteresis		0.3		V	
Input resistance	3	5	7	k $\Omega$	
<b>Timing Characteristics</b>					
Maximum data rate	120	235		kbps	$R_L = 3k\Omega$ , $C_L = 1000pF$ , one driver switching
Driver propagation delay, $t_{PHL}$		1.0		$\mu s$	$R_L = 3k\Omega$ , $C_L = 1000pF$
Driver propagation delay, $t_{PLH}$		1.0		$\mu s$	$R_L = 3k\Omega$ , $C_L = 1000pF$
Receiver propagation delay, $t_{PHL}$		0.3		$\mu s$	Receiver input to receiver output, $C_L = 150pF$
Receiver propagation delay, $t_{PLH}$		0.3		$\mu s$	Receiver input to receiver output, $C_L = 150pF$
Receiver output enable time		200		ns	
Receiver output disable time		200		ns	
Driver skew		100	500	ns	$ t_{PHL} - t_{PLH} $ , $T_{AMB} = 25^{\circ}C$
Receiver skew		200	1000	ns	$ t_{PHL} - t_{PLH} $
Transition-region slew rate			30	V/ $\mu s$	$V_{CC} = 3.3V$ , $R_L = 3k\Omega$ , $C_L = 1000pF$ , $T_{AMB} = 25^{\circ}C$ , measurements taken from $-3.0V$ to $3.0V$ or $3.0V$ to $-3.0V$

**NOTE:**

2. Driver input hysteresis is typically 250mV.

### Typical Performance Characteristics

Unless otherwise noted, the following performance characteristics apply for  $V_{CC} = 3.3V$ , 120kbps data rate, all drivers loaded with  $3k\Omega$ ,  $0.1\mu F$  charge pump capacitors, and  $T_{AMB} = 25^{\circ}C$ .

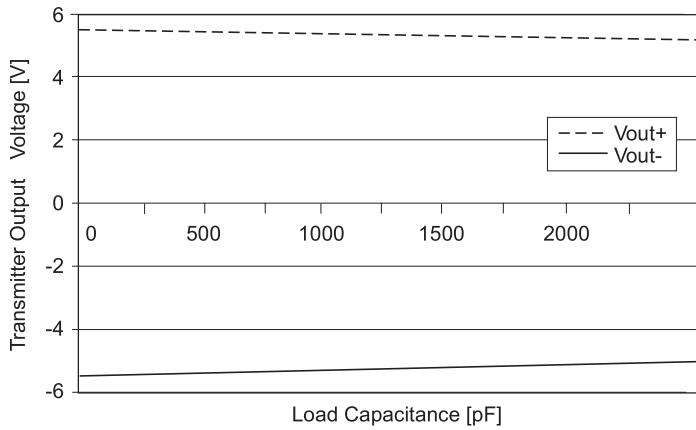

Figure 1: Transmitter Output Voltage vs Load Capacitance for the SP3222E and SP3232E

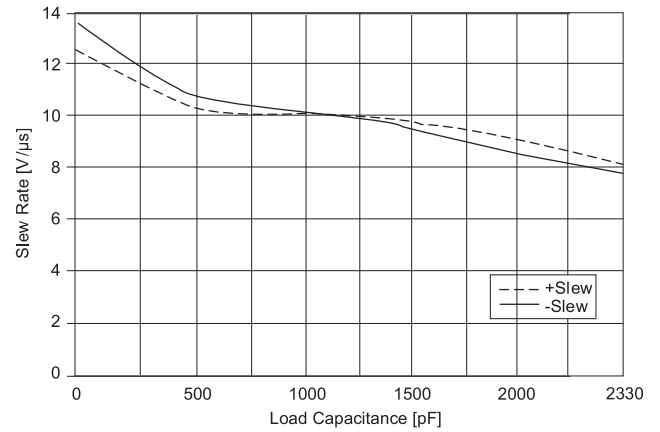

Figure 2: Slew Rate vs Load Capacitance for the SP3222E and SP3232E

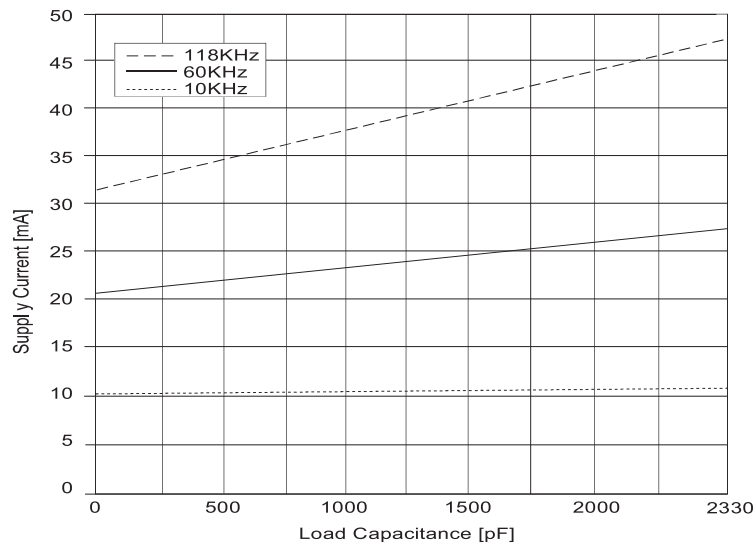

Figure 3: Supply Current VS. Load Capacitance when Transmitting Data

## Pin Functions

Pin Name	Pin Function / Description	Pin Number		
		SP3222E		SP3232E
		SOIC	SSOP TSSOP	
$\overline{\text{EN}}$	Receiver Enable. Apply logic LOW for normal operation. Apply logic HIGH to disable the receiver outputs (high-Z state).	1	1	-
C1+	Positive terminal of the voltage doubler charge-pump capacitor	2	2	1
V+	5.5V output generated by the charge pump	3	3	2
C1-	Negative terminal of the voltage doubler charge-pump capacitor	4	4	3
C2+	Positive terminal of the inverting charge-pump capacitor	5	5	4
C2-	Negative terminal of the inverting charge-pump capacitor	6	6	5
V-	-5.5V output generated by the charge pump	7	7	6
T <sub>1</sub> OUT	RS-232 driver output	15	17	14
T <sub>2</sub> OUT	RS-232 driver output	8	8	7
R <sub>1</sub> IN	RS-232 receiver input	14	16	13
R <sub>2</sub> IN	RS-232 receiver input	9	9	8
R <sub>1</sub> OUT	TTL/CMOS receiver output	13	15	12
R <sub>2</sub> OUT	TTL/CMOS receiver output	10	10	9
T <sub>1</sub> IN	TTL/CMOS driver input	12	13	11
T <sub>2</sub> IN	TTL/CMOS driver input	11	12	10
GND	Ground	16	18	15
V <sub>CC</sub>	3.0V to 5.5V supply voltage	17	19	16
$\overline{\text{SHDN}}$	Shutdown Control Input. Drive HIGH for normal device operation. Drive LOW to shutdown the drivers (high-Z output) and the on-board power supply.	18	20	-
N.C.	No connect	-	11, 14	-

Table 1: Device Pin Description

Pinouts

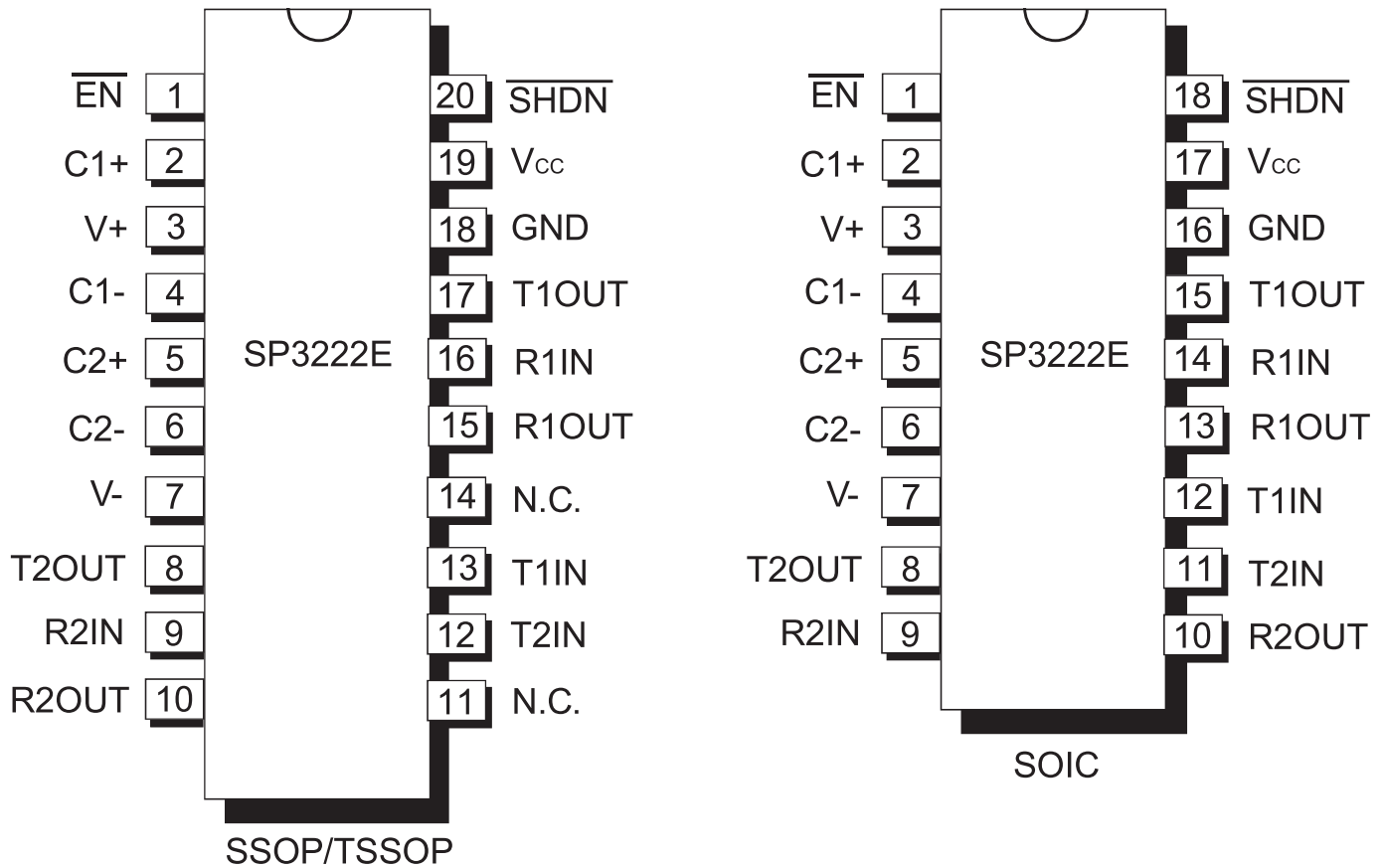

Figure 4: Pinout Configurations for the SP3222E

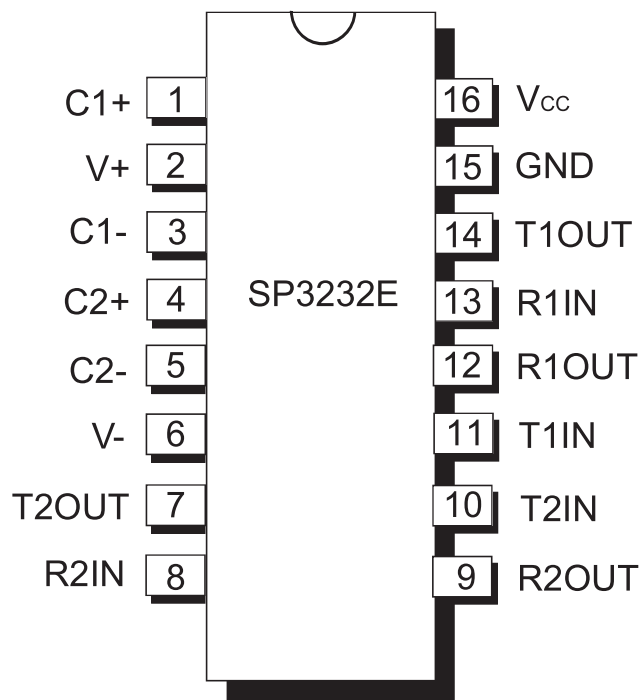

Figure 5: Pinout Configurations for the SP3232E

Typical Operating Circuits

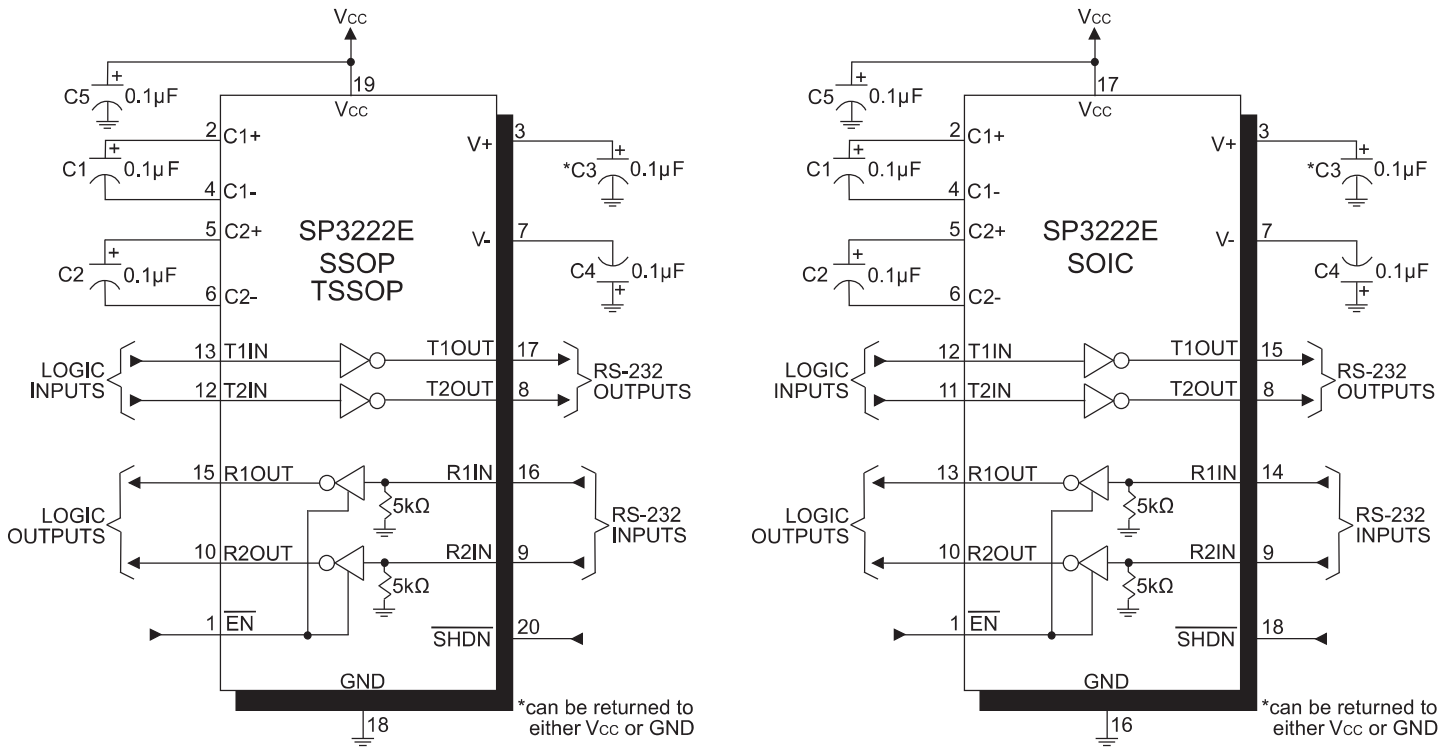

Figure 6: SP3222E Typical Operating Circuits

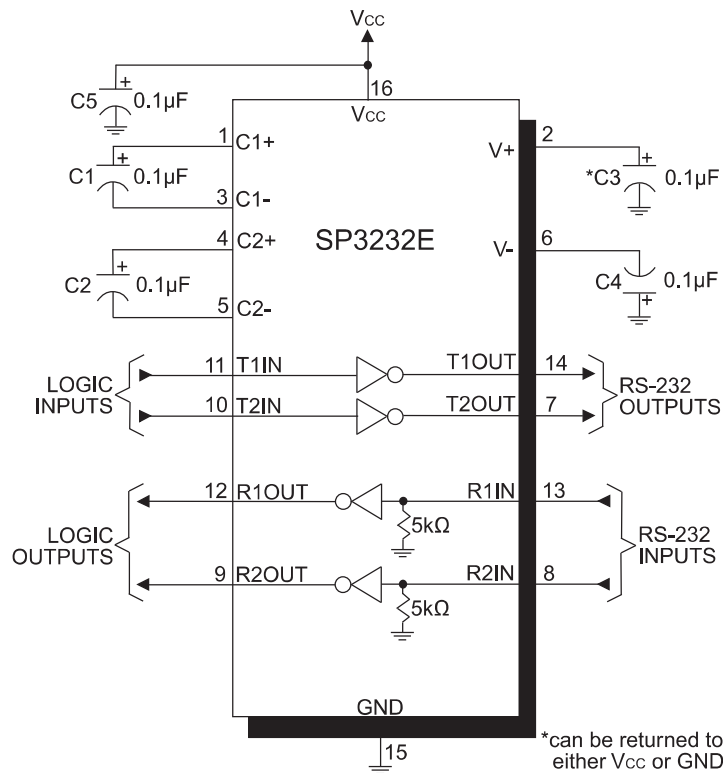

Figure 7: SP3232E Typical Operating Circuit

### Applications Information

The SP3222E / SP3232E transceivers meet the EIA/TIA-232 and ITU-T V.28/V.24 communication protocols and can be implemented in battery-powered, portable, or hand-held applications such as notebook or palmtop computers. The SP3222E / SP3232E devices feature MaxLinear's proprietary on-board charge pump circuitry that generates 5.5V for RS-232 voltage levels from a single 3.0V to 5.5V power supply. This series is ideal for 3.3V-only systems, mixed 3.3V to 5.5V systems, or 5.0V-only systems that require true RS-232 performance. The SP3222E / SP3232E devices can operate at a typical data rate of 235kbps when fully loaded.

The SP3222E and SP3232E are 2-driver / 2-receiver devices ideal for portable or hand-held applications. The SP3222E features a 1µA shutdown mode that reduces power consumption and extends battery life in portable systems. Its receivers remain active in shutdown mode, allowing external devices such as modems to be monitored using only 1µA supply current.

### Theory of Operation

The SP3222E/SP3232E series is made up of three basic circuit blocks:

1. Drivers
2. Receivers
3. The MaxLinear proprietary charge pump

#### Drivers

The drivers are inverting level transmitters that convert TTL or CMOS logic levels to 5.0V EIA/TIA-232 levels with an inverted sense relative to the input logic levels. Typically, the RS-232 output voltage swing is 5.4V with no load and 5V minimum fully loaded. The driver outputs are protected against infinite short-circuits to ground without degradation in reliability. Driver outputs will meet EIA/TIA-562 levels of ±3.7V with supply voltages as low as 2.7V.

The drivers can guarantee a data rate of 120kbps fully loaded with 3kΩ in parallel with 1000pF, ensuring compatibility with PC-to-PC communication software.

The slew rate of the driver is internally limited to a maximum of 30V/µs in order to meet the EIA standards (EIA RS-232D 2.1.7, Paragraph 5). The transition of the loaded output from HIGH to LOW also meet the monotonicity requirements of the standard.

Figure 8 shows a loopback test circuit used to test the RS-232 Drivers. Figure 9 shows the test results of the loopback circuit with all drivers active at 120kbps with RS-232 loads in parallel with a 1000pF capacitor.

Figure 10 shows the test results where one driver was active at 235kbps and all drivers loaded with an RS-232 receiver in parallel with 1000pF capacitors. A solid RS-232 data transmission rate of 120kbps provides compatibility with many designs in personal computer peripherals and LAN applications.

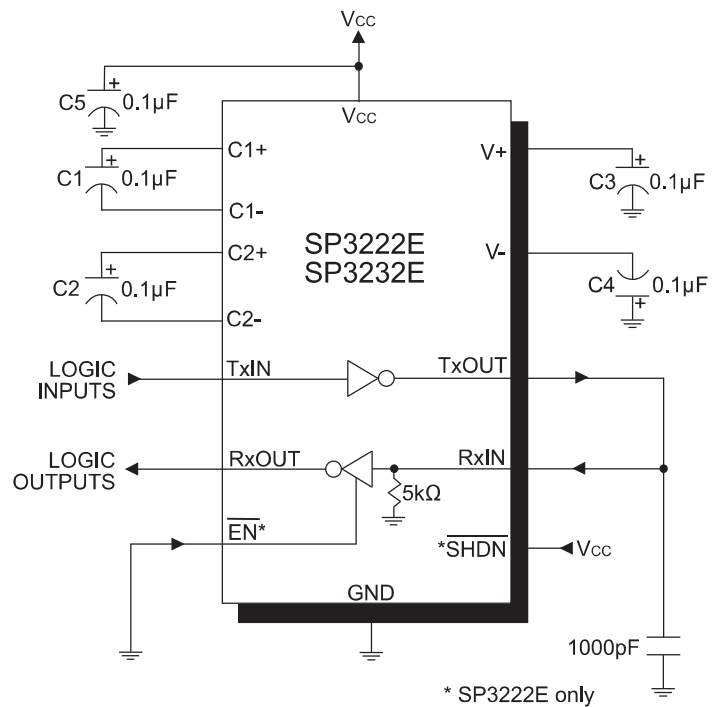

Figure 8: SP3222E/SP3232E Driver Loopback Test Circuit

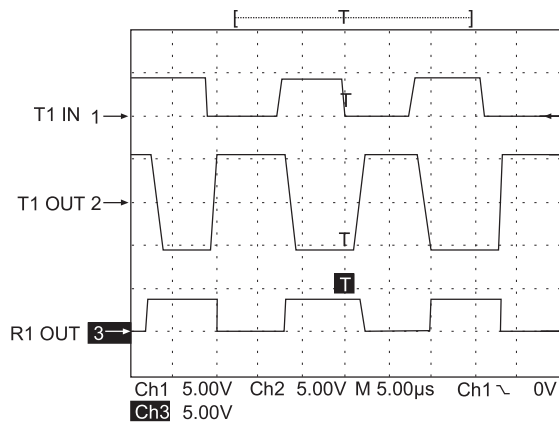

Figure 9: Loopback Test results at 120kbps

Applications Information (Continued)

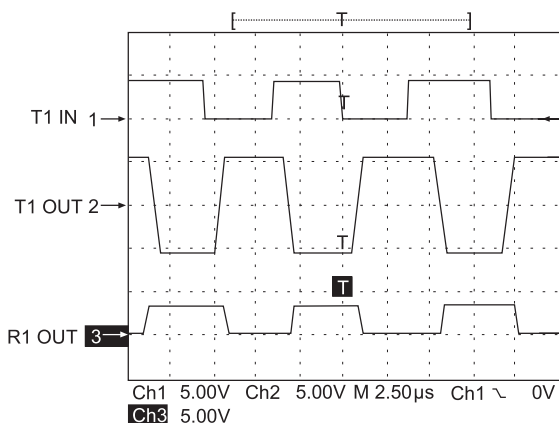

Figure 10: Loopback Test results at 235kbps

The SP3222E driver’s output stages are turned off (tri-state) when the device is in shutdown mode. When the power is off, the SP3222E device permits the outputs to be driven up to ±12V. The driver’s inputs do not have pull-up resistors. Designers should connect unused inputs to  $V_{CC}$  or GND.

In the shutdown mode, the supply current falls to less than 1µA, where  $\overline{SHDN} = \text{LOW}$ . When the SP3222E device is shut down, the device’s driver outputs are disabled (tri-stated) and the charge pumps are turned off with  $V+$  pulled down to  $V_{CC}$  and  $V-$  pulled to GND. The time required to exit shutdown is typically 100µs. Connect  $\overline{SHDN}$  to  $V_{CC}$  if the shutdown mode is not used.

Receivers

The Receivers convert EIA/TIA-232 levels to TTL or CMOS logic output levels. The SP3222E receivers have an inverting tri-state output. These receiver outputs (RxOUT) are tri-stated when the enable control  $\overline{EN} = \text{HIGH}$ . In the shutdown mode, the receivers can be active or inactive.  $\overline{EN}$  has no effect on TxOUT. The truth table logic of the SP3222E driver and receiver outputs can be found in Table 2.

$\overline{SHDN}$	$\overline{EN}$	TxOUT	RxOUT
0	0	Tri-state	Active
0	1	Tri-state	Tri-state
1	0	Active	Active
1	1	Active	Tri-state

Table 2: SP3222E Truth Table Logic for Shutdown and Enable Control

Since receiver input is usually from a transmission line where long cable lengths and system interference can degrade the signal, the inputs have a typical hysteresis margin of 300mV. This ensures that the receiver is virtually immune to noisy transmission lines. Should an input be left unconnected, an internal 5kΩ pulldown resistor to ground will commit the output of the receiver to a HIGH state.

Charge Pump

The charge pump is an MaxLinear-patented design (U.S. 5,306,954) and uses a unique approach compared to older less-efficient designs. The charge pump still requires four external capacitors, but uses a four-phase voltage shifting technique to attain symmetrical 5.5V power supplies. The internal power supply consists of a regulated dual charge pump that provides output voltages of ±5.5V regardless of the input voltage ( $V_{CC}$ ) over the 3.0V to 5.5V range.

In most circumstances, decoupling the power supply can be achieved adequately using a 0.1µF bypass capacitor at C5 (refer to figures 6 and 7). In applications that are sensitive to power-supply noise, decouple  $V_{CC}$  to ground with a capacitor of the same value as charge-pump capacitor C1. Physically connect bypass capacitors as close to the IC as possible.

The charge pump operates in a discontinuous mode using an internal oscillator. If the output voltages are less than a magnitude of 5.5V, the charge pump is enabled. If the output voltages exceed a magnitude of 5.5V, the charge pump is disabled. This oscillator controls the four phases of the voltage shifting. A description of each phase follows.

Phase 1:  $V_{SS}$  charge storage

During this phase of the clock cycle, the positive side of capacitors  $C_1$  and  $C_2$  are initially charged to  $V_{CC}$ .  $C_1^+$  is then switched to GND and the charge in  $C_1^-$  is transferred to  $C_2^-$ . Since  $C_2^+$  is connected to  $V_{CC}$ , the voltage potential across capacitor  $C_2$  is now 2 times  $V_{CC}$ .

Phase 2:  $V_{SS}$  transfer

Phase two of the clock connects the negative terminal of  $C_2$  to the  $V_{SS}$  storage capacitor and the positive terminal of  $C_2$  to GND. This transfers a negative generated voltage to  $C_3$ . This generated voltage is regulated to a minimum voltage of -5.5V. Simultaneous with the transfer of the voltage to  $C_3$ , the positive side of capacitor  $C_1$  is switched to  $V_{CC}$  and the negative side is connected to GND.

## Applications Information (Continued)

### Phase 3: $V_{DD}$ charge storage

The third phase of the clock is identical to the first phase; the charge transferred in  $C_1$  produces  $-V_{CC}$  in the negative terminal of  $C_1$ , which is applied to the negative side of capacitor  $C_2$ . Since  $C_2^+$  is at  $V_{CC}$ , the voltage potential across  $C_2$  is 2 times  $V_{CC}$ .

### Phase 4: $V_{DD}$ transfer

The fourth phase of the clock connects the negative terminal of  $C_2$  to GND, and transfers this positive generated voltage across  $C_2$  to  $C_4$ , the  $V_{DD}$  storage capacitor. This voltage is regulated to 5.5V. At this voltage, the internal oscillator is disabled. Simultaneous with the transfer of the voltage to  $C_4$ , the positive side of capacitor  $C_1$  is switched to  $V_{CC}$  and the negative side is disconnected to GND, allowing the charge pump cycle to begin again. The charge pump cycle will continue as long as the operational conditions for the internal oscillator are present.

Since both  $V^+$  and  $V^-$  are separately generated from  $V_{CC}$ , in a no-load condition  $V^+$  and  $V^-$  will be symmetrical. Older charge pump approaches that generate  $V^-$  from  $V^+$  will show a decrease in the magnitude of  $V^-$  compared to  $V^+$  due to the inherent inefficiencies in the design.

The clock rate for the charge pump typically operates at greater than 250kHz. The external capacitors can be as low as 0.1 $\mu$ F with a 16V breakdown voltage rating.

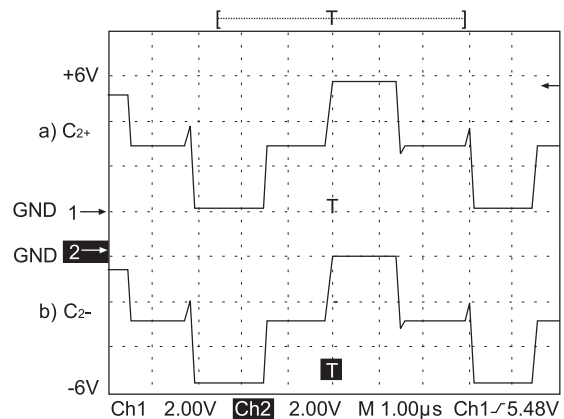

Figure 13: Charge Pump Waveforms

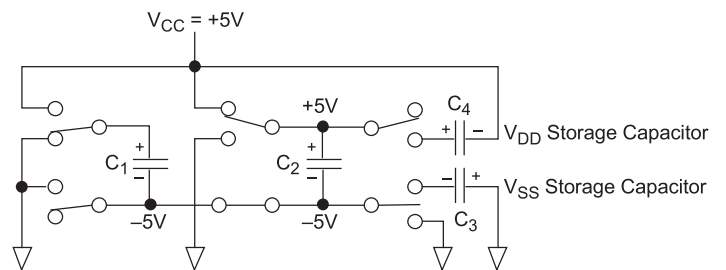

Figure 14: Charge Pump - Phase 3

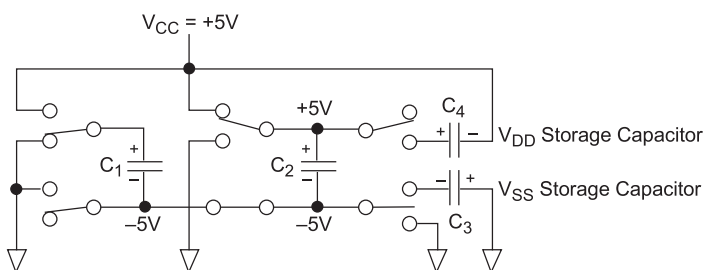

Figure 11: Charge Pump - Phase 1

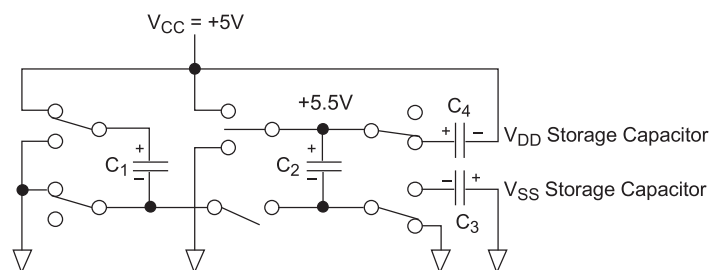

Figure 15: Charge Pump - Phase 4

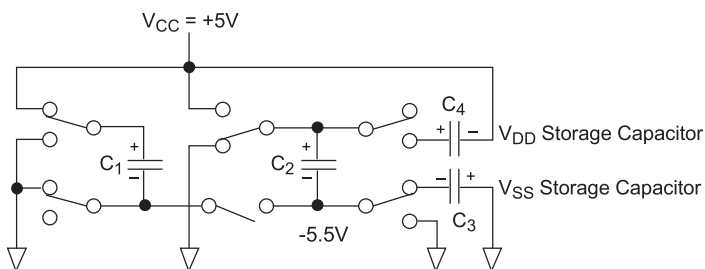

Figure 12: Charge Pump - Phase 2

### ESD Tolerance

The SP3222E / SP3232E Series incorporates ruggedized ESD cells on all driver output and receiver input pins. The ESD structure is improved over our previous family for more rugged applications and environments sensitive to electrostatic discharges and associated transients. The improved ESD tolerance is at least  $\pm 15\text{kV}$  without damage or latch-up.

There are different methods of ESD testing applied:

- a) MIL-STD-883, Method 3015.7
- b) IEC61000-4-2 Air-Discharge
- c) IEC61000-4-2 Direct Contact

The Human Body Model has been the generally accepted ESD testing method for semiconductors. This method is also specified in MIL-STD-883, Method 3015.7 for ESD testing. The premise of this ESD test is to simulate the human body's potential to store electro-static energy and

discharge it to an integrated circuit. The simulation is performed by using a test model as shown in Figure 16. This method will test the IC's capability to withstand an ESD transient during normal handling such as in manufacturing areas where the IC's tend to be handled frequently.

The IEC61000-4-2, formerly IEC801-2, is generally used for testing ESD on equipment and systems. For system manufacturers, they must guarantee a certain amount of ESD protection since the system itself is exposed to the outside environment and human presence. The premise with IEC61000-4-2 is that the system is required to withstand an amount of static electricity when ESD is applied to points and surfaces of the equipment that are accessible to personnel during normal usage. The transceiver IC receives most of the ESD current when the ESD source is applied to the connector pins. The test circuit for IEC61000-4-2 is shown on Figure 17. There are two methods within IEC61000-4-2, the Air Discharge method and the Contact Discharge method.

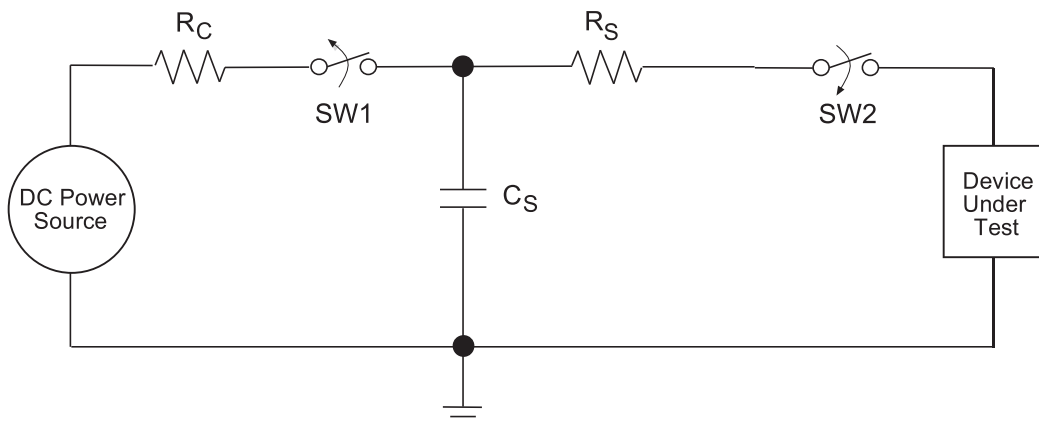

Figure 16: ESD Test Circuit for Human Body Model

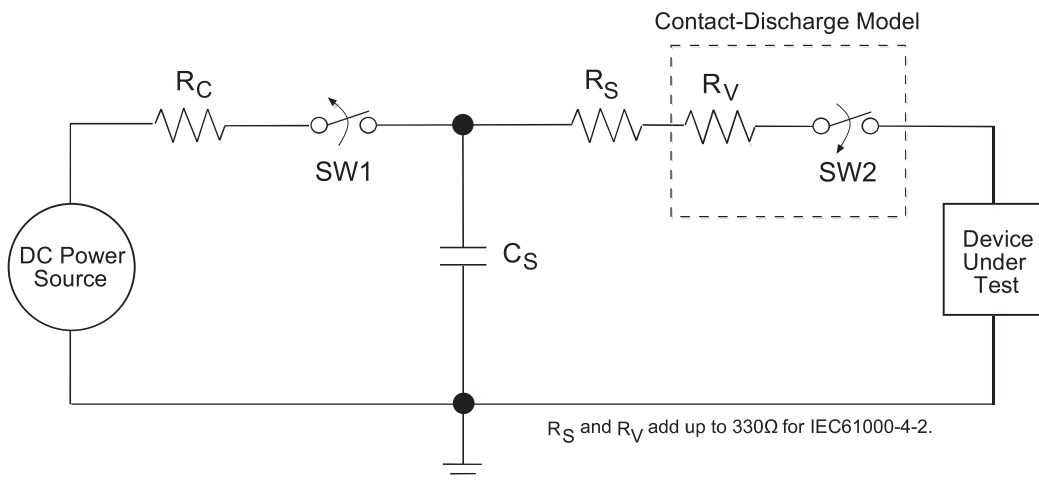

Figure 17: ESD Test Circuit for IEC61000-4-2

**ESD Tolerance (Continued)**

With the Air Discharge Method, an ESD voltage is applied to the equipment under test (EUT) through air. This simulates an electrically charged person ready to connect a cable onto the rear of the system only to find an unpleasant zap just before the person touches the back panel. The high energy potential on the person discharges through an arcing path to the rear panel of the system before he or she even touches the system. This energy, whether discharged directly or through air, is predominantly a function of the discharge current rather than the discharge voltage. Variables with an air discharge such as approach speed of the object carrying the ESD potential to the system and humidity will tend to change the discharge current. For example, the rise time of the discharge current varies with the approach speed.

The Contact Discharge Method applies the ESD current directly to the EUT. This method was devised to reduce the unpredictability of the ESD arc. The discharge current rise time is constant since the energy is directly transferred without the air-gap arc. In situations such as hand held systems, the ESD charge can be directly discharged to the equipment from a person already holding the equipment. The current is transferred on to the keypad or the serial port of the equipment directly and then travels through the PCB and finally to the IC.

The circuit model in Figures 16 and 17 represent the typical ESD testing circuit used for all three methods. The CS is initially charged with the DC power supply when the first switch (SW1) is on. Now that the capacitor is charged, the second switch (SW2) is on while SW1 switches off. The voltage stored in the capacitor is then applied through RS, the current limiting resistor, onto the device under test (DUT). In ESD tests, the SW2 switch is pulsed so that the device under test receives a duration of voltage.

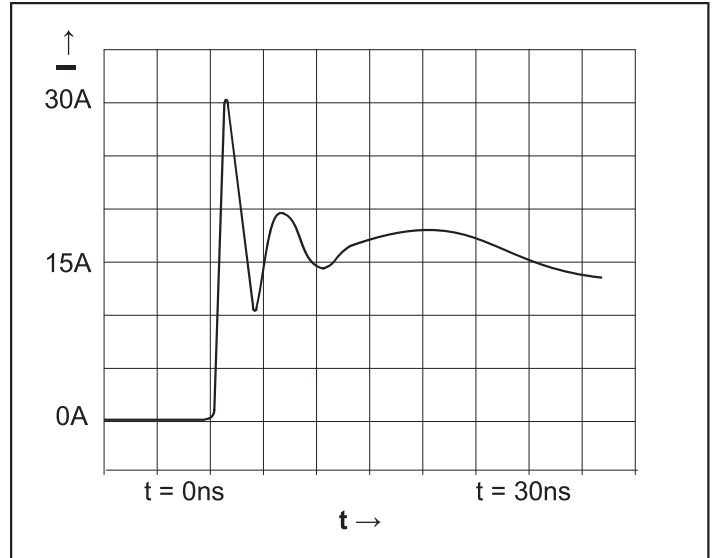

Figure 18: ESD Test Waveform for IEC61000-4-2

For the Human Body Model, the current limiting resistor (RS) and the source capacitor (CS) are 1.5kΩ and 100pF, respectively. For IEC-61000-4-2, the current limiting resistor (RS) and the source capacitor (CS) are 330Ω and 150pF, respectively.

The higher CS value and lower RS value in the IEC61000-4-2 model are more stringent than the Human Body Model. The larger storage capacitor injects a higher voltage to the test point when SW2 is switched on. The lower current limiting resistor increases the current charge onto the test point.

DEVICE PIN TESTED	HUMAN BODY MODEL	IEC61000-4-2		
		Air Discharge	Direct Contact	Level
Driver Outputs	±15kV	±15kV	±8kV	4
Receiver Inputs	±15kV	±15kV	±8kV	4

Table 3: Transceiver ESD Tolerance Levels

Mechanical Dimensions

SSOP20

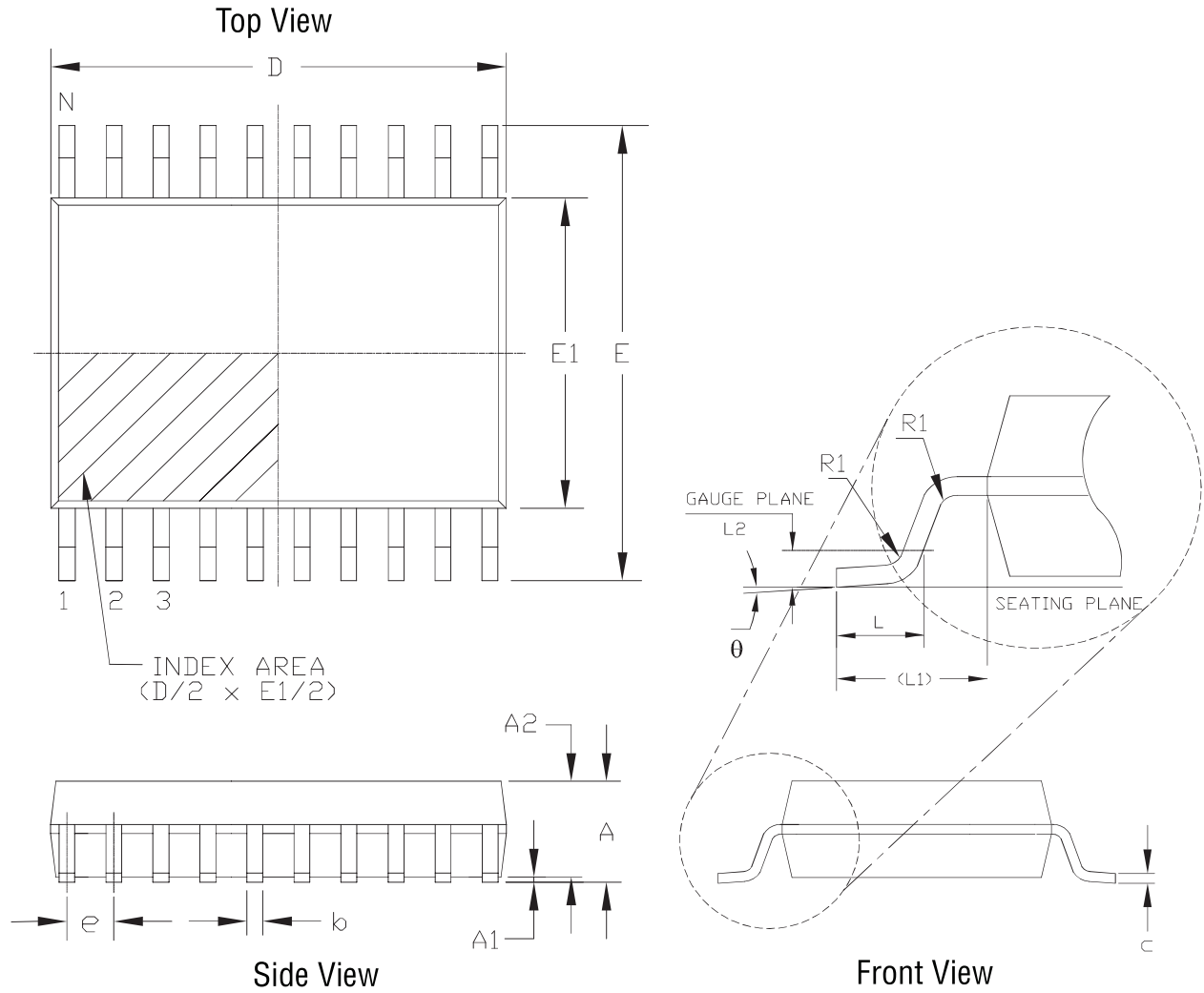

PACKAGE OUTLINE SSOP 5.3mm BODY JEDEC MO-150 VARIATION AE						
SYMBOLS	COMMON DIMENSIONS IN MM (Control Unit)			COMMON DIMENSIONS IN INCH (Reference Unit)		
	MIN	NOM	MAX	MIN	NOM	MAX
A	—	—	2.00	—	—	0.079
A1	0.05	—	—	0.002	—	—
A2	1.65	1.75	1.85	0.065	0.069	0.073
b	0.22	—	0.38	0.009	—	0.015
c	0.09	—	0.25	0.004	—	0.010
E	7.40	7.80	8.20	0.291	0.307	0.323
E1	5.00	5.30	5.60	0.197	0.209	0.220
e	0.65 BSC			0.026 BSC		
L	0.55	0.75	0.95	0.022	0.030	0.037
L1	1.25 REF			0.049 REF		
L2	0.25 BSC			0.010 BSC		
R1	0.09	—	—	0.004	—	—
θ	0°	4°	8°	0°	4°	8°
D	6.90	7.20	7.50	.272	0.283	0.295
N	20					

Drawing No: POD-00000119

Revision: A

Mechanical Dimensions

SSOP16

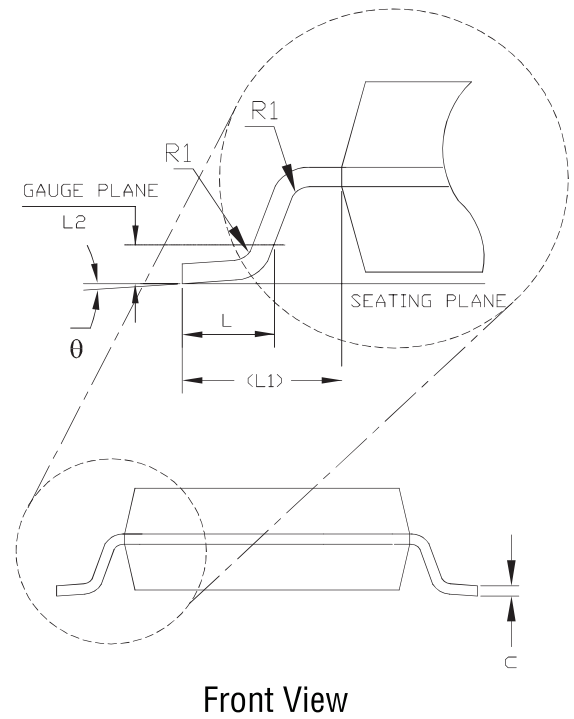
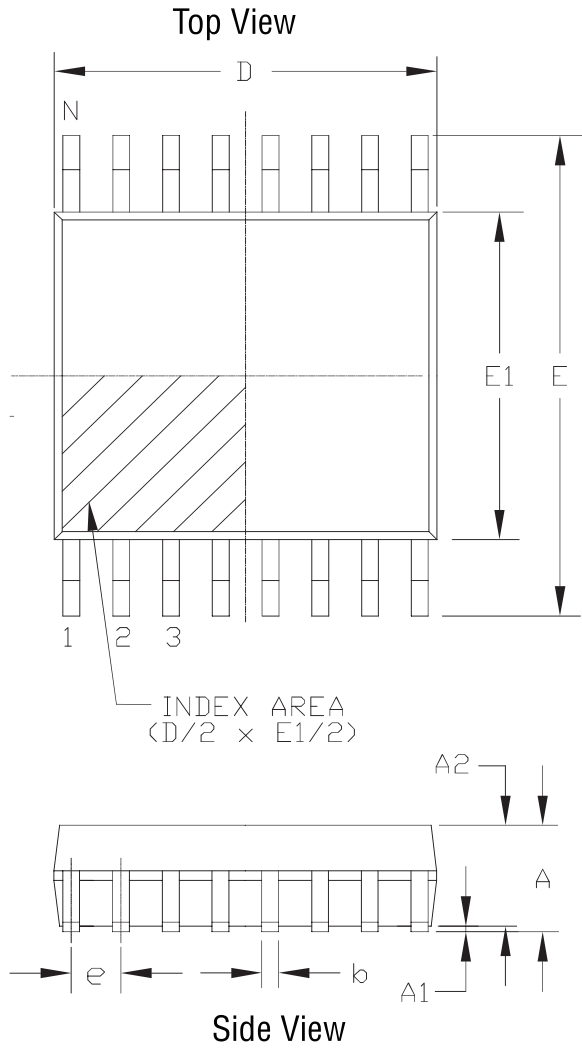

PACKAGE OUTLINE SSOP 5.3mm BODY JEDEC MO-150 VARIATION AC						
SYMBOLS	COMMON DIMENSIONS IN MM (Control Unit)			COMMON DIMENSIONS IN INCH (Reference Unit)		
	MIN	NOM	MAX	MIN	NOM	MAX
A	—	—	2.00	—	—	0.079
A1	0.05	—	—	0.002	—	—
A2	1.65	1.75	1.85	0.065	0.069	0.073
b	0.22	—	0.38	0.009	—	0.015
c	0.09	—	0.25	0.004	—	0.010
E	7.40	7.80	8.20	0.291	0.307	0.323
E1	5.00	5.30	5.60	0.197	0.209	0.220
e	0.65 BSC			0.026 BSC		
L	0.55	0.75	0.95	0.022	0.030	0.037
L1	1.25 REF			0.049 REF		
L2	0.25 BSC			0.010 BSC		
R1	0.09	—	—	0.004	—	—
$\theta$	0°	4°	8°	0°	4°	8°
D	5.90	6.20	6.50	0.232	0.244	0.256
N	16					

Drawing No: POD-00000116

Revision: A

Mechanical Dimensions

WSOIC16

Top View

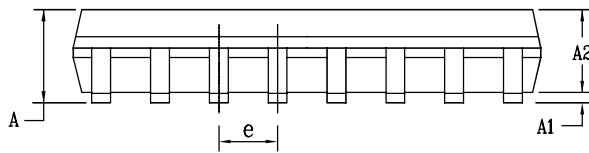
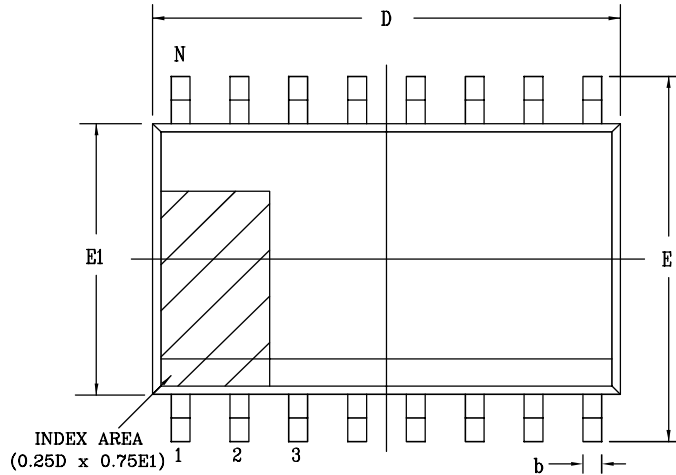

Side View

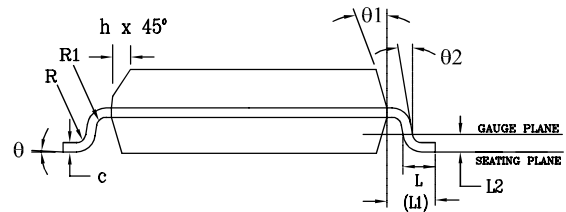

Front View

PACKAGE OUTLINE SOIC .300" BODY JEDEC MS-013 VARIATION AA						
SYMBOLS	COMMON DIMENSIONS IN MM (Control Unit)			COMMON DIMENSIONS IN INCHES (Reference Unit)		
	MIN	NOM	MAX	MIN	NOM	MAX
A	2.35	—	2.65	0.093	—	0.104
A1	0.10	—	0.30	0.004	—	0.012
A2	2.05	—	2.55	0.081	—	0.100
b	0.31	—	0.51	0.012	—	0.020
c	0.20	—	0.33	0.008	—	0.013
E	10.30 BSC			0.406 BSC		
E1	7.50 BSC			0.295 BSC		
e	1.27 BSC			0.050 BSC		
h	0.25	—	0.75	0.010	—	0.030
L	0.40	—	1.27	0.016	—	0.050
L1	1.40 REF			0.055 REF		
L2	0.25 BSC			0.010 BSC		
R	0.07	—	—	0.003	—	—
R1	0.07	—	—	0.003	—	—
theta	0°	—	8°	0°	—	8°
theta1	5°	—	15°	5°	—	15°
theta2	0°	—	—	0°	—	—
D	10.30 BSC			0.405 BSC		
N	16					

Drawing No: POD-00000115

Revision: B

Mechanical Dimensions

WSOIC18

Top View

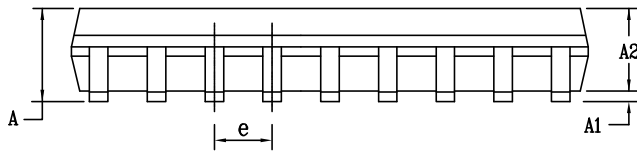
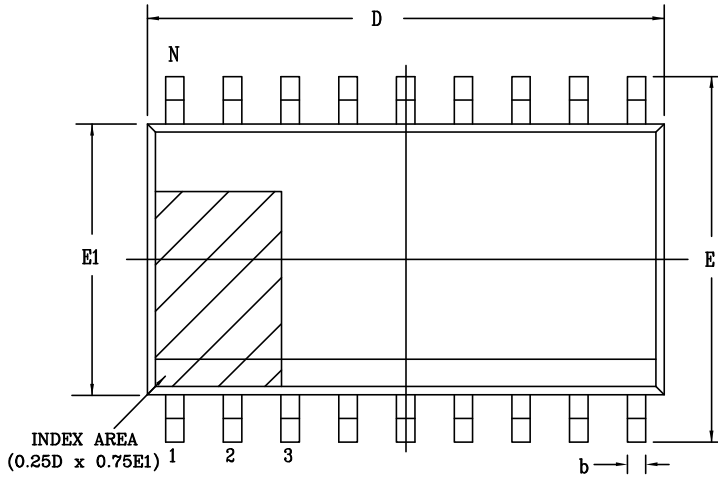

Side View

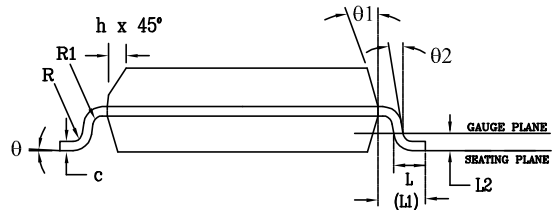

Front View

PACKAGE OUTLINE SOIC .300" BODY JEDEC MS-013 VARIATION AB						
SYMBOLS	COMMON DIMENSIONS IN MM (Control Unit)			COMMON DIMENSIONS IN INCHES (Reference Unit)		
	MIN	NOM	MAX	MIN	NOM	MAX
A	2.35	—	2.65	0.093	—	0.104
A1	0.10	—	0.30	0.004	—	0.012
A2	2.05	—	2.55	0.081	—	0.100
b	0.31	—	0.51	0.012	—	0.020
c	0.20	—	0.33	0.008	—	0.013
E	10.30 BSC			0.406 BSC		
E1	7.50 BSC			0.295 BSC		
e	1.27 BSC			0.050 BSC		
h	0.25	—	0.75	0.010	—	0.030
L	0.40	—	1.27	0.016	—	0.050
L1	1.40 REF			0.055 REF		
L2	0.25 BSC			0.010 BSC		
R	0.07	—	—	0.003	—	—
R1	0.07	—	—	0.003	—	—
θ	0°	—	8°	0°	—	8°
θ1	5°	—	15°	5°	—	15°
θ2	0°	—	—	0°	—	—
D	11.55 BSC			0.455 BSC		
N	18					

Drawing No: POD-00000118

Revision: B

Mechanical Dimensions

NSOIC16

Top View

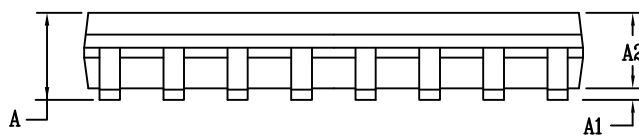
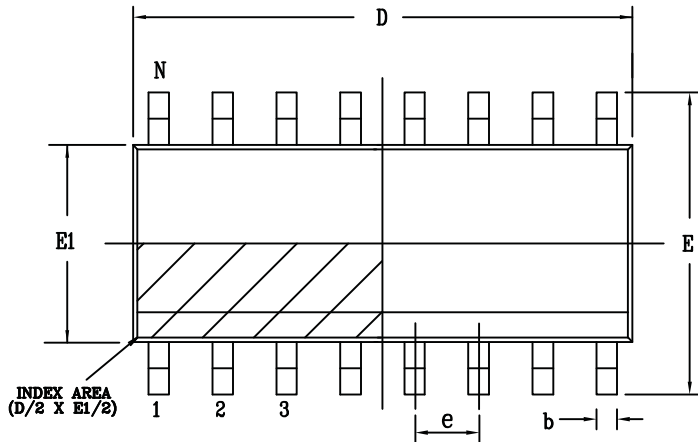

Side View

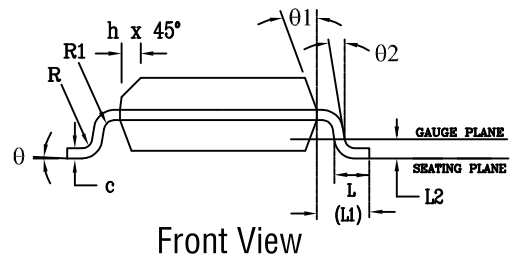

Front View

PACKAGE OUTLINE NSOIC .150" BODY JEDEC MS-012 VARIATION AC						
SYMBOLS	COMMON DIMENSIONS IN MM (Control Unit)			COMMON DIMENSIONS IN INCH (Reference Unit)		
	MIN	NOM	MAX	MIN	NOM	MAX
A	1.35	—	1.75	0.053	—	0.069
A1	0.10	—	0.25	0.004	—	0.010
A2	1.25	—	1.65	0.049	—	0.065
b	0.31	—	0.51	0.012	—	0.020
c	0.17	—	0.25	0.007	—	0.010
E	6.00 BSC			0.236 BSC		
E1	3.90 BSC			0.154 BSC		
e	1.27 BSC			0.050 BSC		
h	0.25	—	0.50	0.010	—	0.020
L	0.40	—	1.27	0.016	—	0.050
L1	1.04 REF			0.041 REF		
L2	0.25 BSC			0.010 BSC		
R	0.07	—	—	0.003	—	—
R1	0.07	—	—	0.003	—	—
q	0°	—	8°	0°	—	8°
q1	5°	—	15°	5°	—	15°
q2	0°	—	—	0°	—	—
D	9.90 BSC			0.390 BSC		
N	16					

Drawing No: POD-00000114

Revision: A

Mechanical Dimensions

TSSOP16

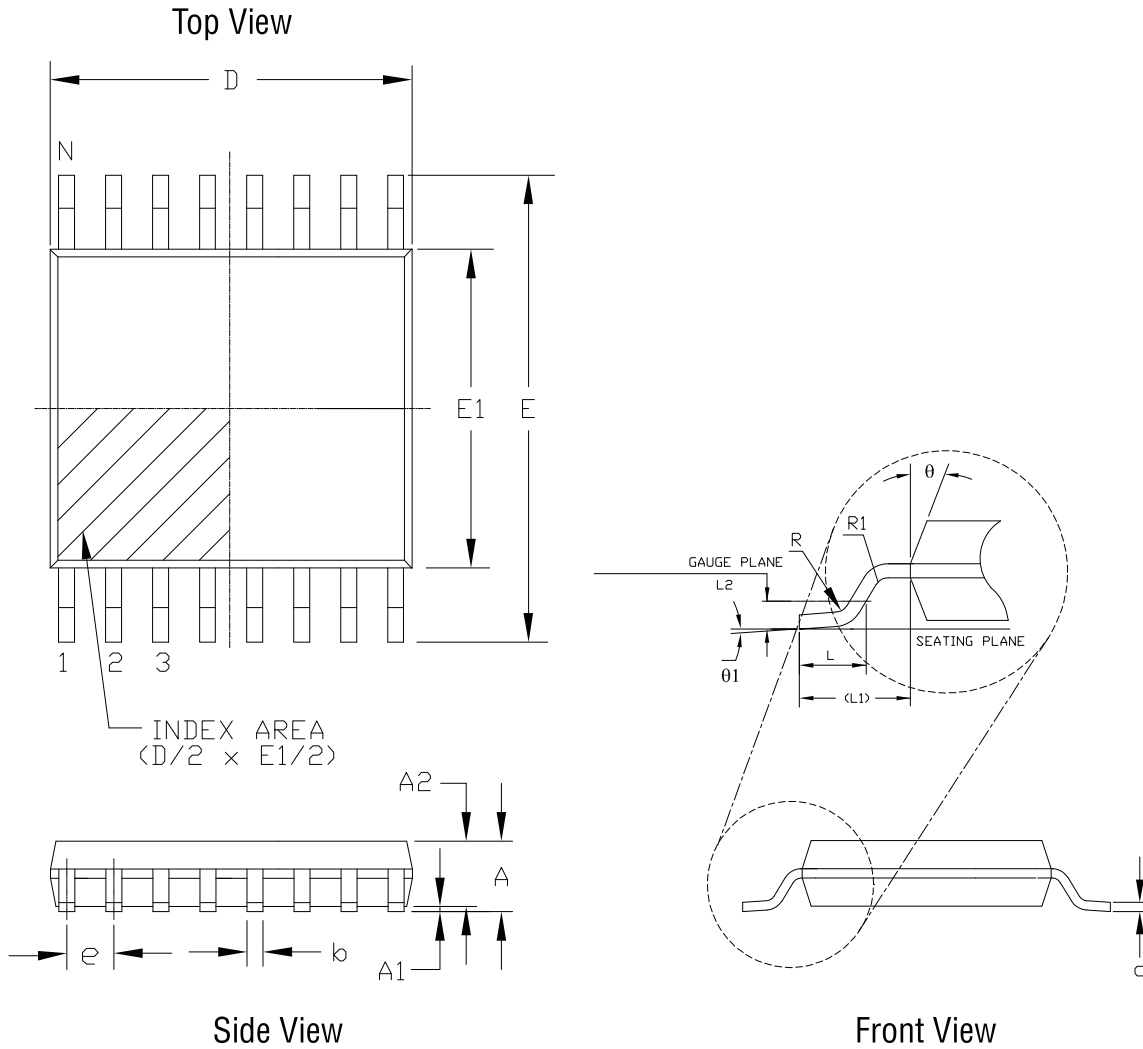

16 Pin TSSOP JEDEC MO-153 Variation AB						
SYMBOLS	DIMENSIONS IN MM (Control Unit)			DIMENSIONS IN INCH (Reference Unit)		
	MIN	NOM	MAX	MIN	NOM	MAX
A	—	—	1.20	—	—	0.047
A1	0.05	—	0.15	0.002	—	0.006
A2	0.80	1.00	1.05	0.031	0.039	0.041
b	0.19	—	0.30	0.007	—	0.012
c	0.09	—	0.20	0.004	—	0.008
E	6.40 BSC			0.252 BSC		
E1	4.30	4.40	4.50	0.169	0.173	0.177
e	0.65 BSC			0.026 BSC		
L	0.45	0.60	0.75	0.018	0.024	0.030
L1	1.00 REF			0.039 REF		
L2	0.25 BSC			0.010 BSC		
R	0.09	—	—	0.035	—	—
R1	0.09	—	—	0.035	—	—
θ	12° REF			12° REF		
θ1	0°	—	8°	0°	—	8°
D	4.90	5.00	5.10	0.193	0.197	0.200
N	16			16		

Drawing No: POD-00000117

Revision: A

Mechanical Dimensions

TSSOP20

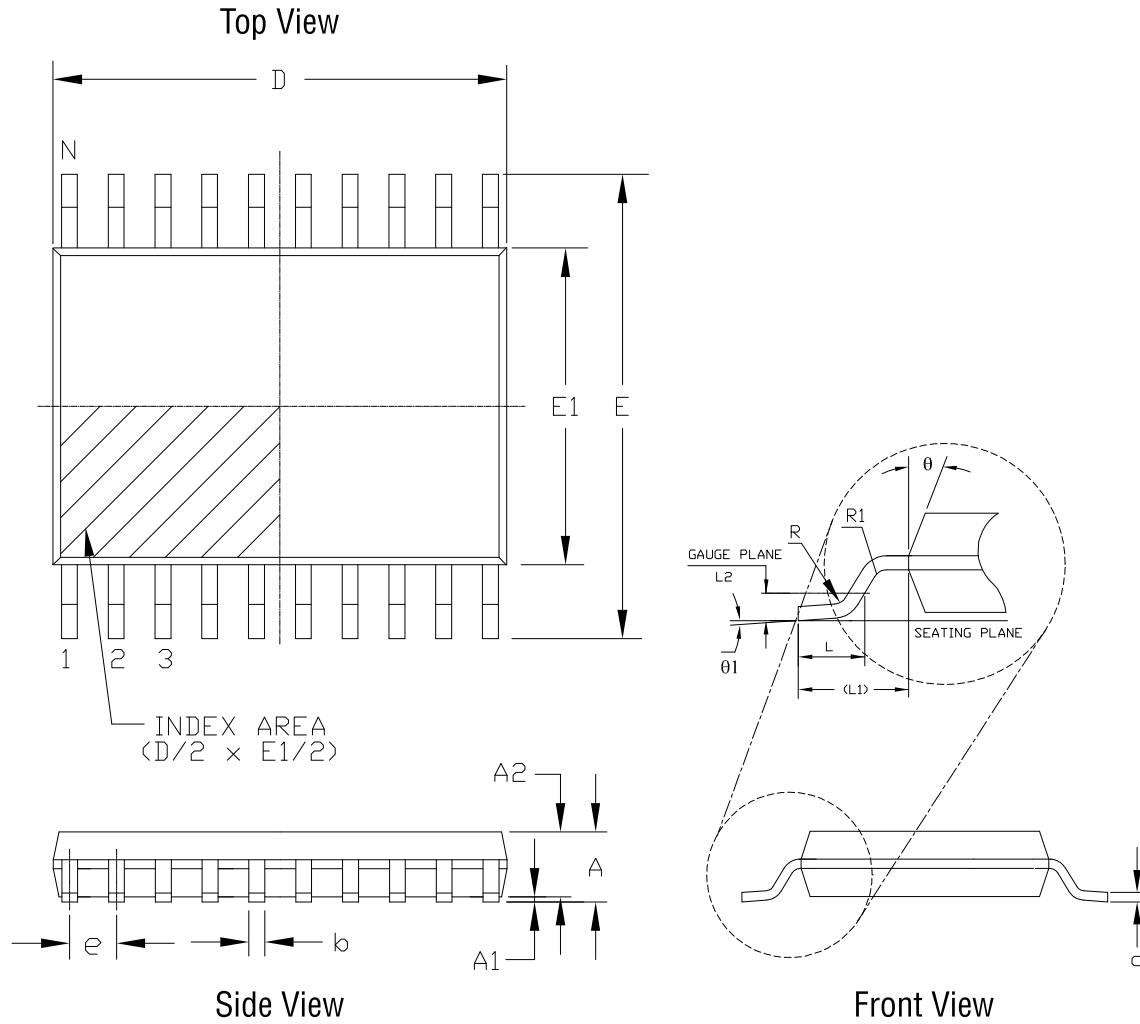

20 Pin TSSOP JEDEC MO-153 Variation AC						
SYMBOLS	DIMENSIONS IN MM (Control Unit)			DIMENSIONS IN INCH (Reference Unit)		
	MIN	NOM	MAX	MIN	NOM	MAX
A	—	—	1.20	—	—	0.047
A1	0.05	—	0.15	0.002	—	0.006
A2	0.80	1.00	1.05	0.031	0.039	0.041
b	0.19	—	0.30	0.007	—	0.012
c	0.09	—	0.20	0.004	—	0.008
E	6.40 BSC			0.252 BSC		
E1	4.30	4.40	4.50	0.169	0.173	0.177
e	0.65 BSC			0.026 BSC		
L	0.45	0.60	0.75	0.018	0.024	0.030
L1	1.00 REF			0.039 REF		
L2	0.25 BSC			0.010 BSC		
R	0.09	—	—	0.035	—	—
R1	0.09	—	—	0.035	—	—
θ	12° REF			12° REF		
θ1	0°	—	8°	0°	—	8°
D	6.40	6.50	6.60	0.252	0.256	0.260
N	20			20		

Drawing No: POD-00000120

Revision: A

Ordering Information<sup>(1)</sup>

Part Number	Operating Temperature Range	Package	Packaging Method	Lead-Free <sup>(2)</sup>
<b>SP3222E</b>				
SP3222ECA-L/TR	0°C to +70°C	20 Pin SSOP	Reel	Yes
SP3222ECT-L/TR	0°C to +70°C	18 Pin WSOIC	Reel	Yes
SP3222ECY-L/TR	0°C to +70°C	20 Pin TSSOP	Reel	Yes
SP3222EEA-L/TR	-40°C to +85°C	20 Pin SSOP	Reel	Yes
SP3222EEY-L/TR	-40°C to +85°C	20 Pin TSSOP	Reel	Yes
<b>SP3232E</b>				
SP3232ECA-L	0°C to +70°C	16 Pin SSOP	Tube	Yes
SP3232ECA-L/TR	0°C to +70°C	16 Pin SSOP	Reel	Yes
SP3232ECN-L	0°C to +70°C	16 Pin NSOIC	Tube	Yes
SP3232ECN-L/TR	0°C to +70°C	16 Pin NSOIC	Reel	Yes
SP3232ECT-L/TR	0°C to +70°C	16 Pin WSOIC	Reel	Yes
SP3232ECY-L	0°C to +70°C	16 Pin TSSOP	Tube	Yes
SP3232ECY-L/TR	0°C to +70°C	16 Pin TSSOP	Reel	Yes
SP3232EEA-L	-40°C to +85°C	16 Pin SSOP	Tube	Yes
SP3232EEA-L/TR	-40°C to +85°C	16 Pin SSOP	Reel	Yes
SP3232EEN-L	-40°C to +85°C	16 Pin NSOIC	Tube	Yes
SP3232EEN-L/TR	-40°C to +85°C	16 Pin NSOIC	Reel	Yes
SP3232EET-L	-40°C to +85°C	16 Pin WSOIC	Tube	Yes
SP3232EET-L/TR	-40°C to +85°C	16 Pin WSOIC	Reel	Yes
SP3232EEY-L	-40°C to +85°C	16 Pin TSSOP	Tube	Yes
SP3232EEY-L/TR	-40°C to +85°C	16 Pin TSSOP	Reel	Yes

NOTE:

1. Refer to [www.maxlinear.com/SP3222E](http://www.maxlinear.com/SP3222E) and [www.maxlinear.com/SP3232E](http://www.maxlinear.com/SP3232E) for most up-to-date Ordering Information.
2. Visit [www.maxlinear.com](http://www.maxlinear.com) for additional information on Environmental Rating.

Selection Table

MODEL	Power Supplies	RS-232 Drivers	RS-232 Receivers	External Components	Shutdown	TTL 3-State	# of Pins
SP3222E	+3.0V to +5.5V	2	2	4 Capacitors	Yes	Yes	18, 20
SP3232E	+3.0V to +5.5V	2	2	4 Capacitors	No	No	16

## Revision History

Revision	Date	Description
08/22/05	--	Legacy Sipex Datasheet
12/08/10	1.0.0	Convert to Exar Format and update ordering information.
03/14/13	1.0.1	Correct type error to driver Transition-Region Slew Rate conditions.
10/16/17	1.0.2	Correct SP3222E nSOIC pinout to SOIC. Updated to MaxLinear logo. Updated format and ordering information table.
04/22/20	1.0.3	Change RxIN absolute maximum from $\pm 15V$ to $\pm 25V$ . Update Ordering Information.



**Corporate Headquarters:**  
 5966 La Place Court  
 Suite 100  
 Carlsbad, CA 92008  
 Tel.: +1 (760) 692-0711  
 Fax: +1 (760) 444-8598  
[www.maxlinear.com](http://www.maxlinear.com)

The content of this document is furnished for informational use only, is subject to change without notice, and should not be construed as a commitment by MaxLinear, Inc. MaxLinear, Inc. assumes no responsibility or liability for any errors or inaccuracies that may appear in the informational content contained in this guide. Complying with all applicable copyright laws is the responsibility of the user. Without limiting the rights under copyright, no part of this document may be reproduced into, stored in, or introduced into a retrieval system, or transmitted in any form or by any means (electronic, mechanical, photocopying, recording, or otherwise), or for any purpose, without the express written permission of MaxLinear, Inc.

MaxLinear, Inc. does not recommend the use of any of its products in life support applications where the failure or malfunction of the product can reasonably be expected to cause failure of the life support system or to significantly affect its safety or effectiveness. Products are not authorized for use in such applications unless MaxLinear, Inc. receives, in writing, assurances to its satisfaction that: (a) the risk of injury or damage has been minimized; (b) the user assumes all such risks; (c) potential liability of MaxLinear, Inc. is adequately protected under the circumstances.

MaxLinear, Inc. may have patents, patent applications, trademarks, copyrights, or other intellectual property rights covering subject matter in this document. Except as expressly provided in any written license agreement from MaxLinear, Inc., the furnishing of this document does not give you any license to these patents, trademarks, copyrights, or other intellectual property.

MaxLinear, the MaxLinear logo, and any MaxLinear trademarks, MxL, Full-Spectrum Capture, FSC, G.now, AirPHY and the MaxLinear logo are all on the products sold, are all trademarks of MaxLinear, Inc. or one of MaxLinear's subsidiaries in the U.S.A. and other countries. All rights reserved. Other company trademarks and product names appearing herein are the property of their respective owners.