

UHF BAND MIXER APPLICATIONS.

Unit in mm

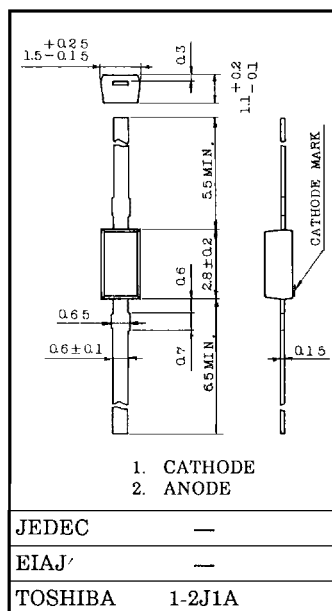

MAXIMUM RATINGS ($T_a = 25^\circ\text{C}$)

CHARACTERISTIC	SYMBOL	RATING	UNIT
Maximum (Peak) Reverse Voltage	V_{RM}	5	V
Forward Current	I_F	30	mA
Junction Temperature	T_j	125	$^\circ\text{C}$
Storage Temperature Range	T_{stg}	-55~125	$^\circ\text{C}$

Weight : 0.02g

ELECTRICAL CHARACTERISTICS ($T_a = 25^\circ\text{C}$)

CHARACTERISTIC	SYMBOL	TEST CONDITION	MIN.	TYP.	MAX.	UNIT
Forward Voltage	V_F	$I_F = 2\text{mA}$	—	0.25	—	V
Forward Current	I_F	$V_F = 0.5\text{V}$	30	—	—	mA
Reverse Current	I_R	$V_R = 0.5\text{V}$	—	—	25	μA
Total Capacitance	C_T	$V_R = 0.2\text{V}, f = 1\text{MHz}$	—	0.6	—	pF

Marking

